

Overview

The Savillex PFA cyclonic spray chamber (CSC) for ICP-MS is manufactured using Savillex's unique stretch blow molding technology, which gives it performance advantages over other inert spray chambers. Unlike other inert cyclonics, which are manufactured from individual machined parts that are assembled or welded together, stretch blow molding allows the Savillex PFA CSC to be molded in an optimum cyclonic shape similar to the traditional shape of a glass or quartz cyclonic. A deep spoiler is molded into the side walls, which improves signal stability and prevents re-nebulization, while a drain guide on the baffle tip promotes smooth draining. Stretch blow molding produces an extremely smooth surface finish, which also improves draining, and its translucent walls allow the user to see inside the chamber during operation. An optional version of the Savillex PFA CSC features a proprietary, organic based surface treatment for improved wettability, which in turn improves aerosol transport efficiency and therefore sensitivity. For a more detailed explanation of the design features of the Savillex PFA CSC, see Savillex Data Sheet DS008. The performance of both versions of the Savillex PFA CSC (surface treated and untreated) was compared to a PFA cyclonic spray chamber from another manufacturer, using ICP-MS. Both versions of the Savillex PFA CSC demonstrated superior signal stability and sensitivity.



Savillex PFA Cyclonic Spray Chamber

Performance Comparison – ICP-MS

The performance of three PFA cyclonic spray chambers were compared using ICP-MS as follows: Savillex PFA CSC (untreated) part number 820-01, Savillex PFA CSC (treated) part number 820-02, which features a surface treatment to improve wettability, and a PFA cyclonic (referred to as "PFA Cyclonic A"). Both Savillex PFA cyclonic Spray Chambers were fitted with exit port/connector part number 821-103, which features a baffle and a 12/5 socket connector. PFA Cyclonic A featured a baffle but had no surface treatment. All three spray chambers were connected to the ICP-MS using a glass elbow with a 12/5 ball connector to a standard quartz torch. No spray chamber cooling was used: spray chambers were operated at ambient temperature (19°C). A Savillex C400d PFA concentric nebulizer, pumped at 350 uL/min was used throughout. A 10 ppb multielement tune solution was measured using 1 point per peak, an integration time of 1 sec/mass and 100 replicates, giving a total measurement time of 650 seconds.

| Spray Chamber | Carrier Gas (SLPM) | Li 7 | | Co 59 | | Y 89 | | Ce 140 | | Ti 205 | | Ce2+ 70/140 | CeO/Ce 156/140 |
|----------------------------|--------------------|--------|---------|---------|---------|---------|---------|---------|---------|---------|---------|----------------|-------------------|
| | | Counts | RSD (%) | Counts | RSD (%) | Counts | RSD (%) | Counts | RSD (%) | Counts | RSD (%) | % | % |
| Savillex PFA CSC Treated | 1.10 | 727979 | 1.7 | 3059697 | 1.8 | 4261087 | 1.7 | 4029454 | 1.7 | 2733285 | 2.0 | 1.10 | 1.30 |
| Savillex PFA CSC Untreated | 1.10 | 499800 | 0.9 | 2092330 | 1.2 | 2961662 | 1.0 | 2807320 | 1.2 | 1883073 | 1.1 | 1.23 | 1.18 |
| PFA Cyclonic A | 1.10 | 431198 | 3.1 | 1916946 | 3.3 | 2678251 | 3.0 | 2521208 | 3.3 | 1541420 | 5.6 | 1.01 | 1.20 |

ICP-MS comparison of two Savillex PFA Cyclonic Spray Chambers and "PFA Cyclonic A" from a different manufacturer. 10 minute stability test.

The table shows short term stability (representative of measurement precision) and sensitivity across the mass range, plus cerium doubly charged and oxide levels. Both versions of the Savillex PFA CSC exhibited superior signal stability compared to PFA Cyclonic A. The untreated Savillex PFA CSC gave higher sensitivity (10-20%) across the mass range than the PFA Cyclonic A, while the sensitivity of the treated Savillex PFA CSC was significantly higher (60%) than PFA Cyclonic A. As a reference, the treated Savillex PFA CSC has equivalent sensitivity to a glass or quartz cyclonic. It is thought that surface treatment enhances sensitivity because the improved wettability reduces droplet formation on the side walls. Without surface treatment, these droplets absorb sample aerosol and reduce aerosol transmission. For ultratrace applications such as semiconductor using ICP-MS, the untreated version is recommended. For applications that require maximum sensitivity (including all ICP-OES applications), the treated version is recommended.

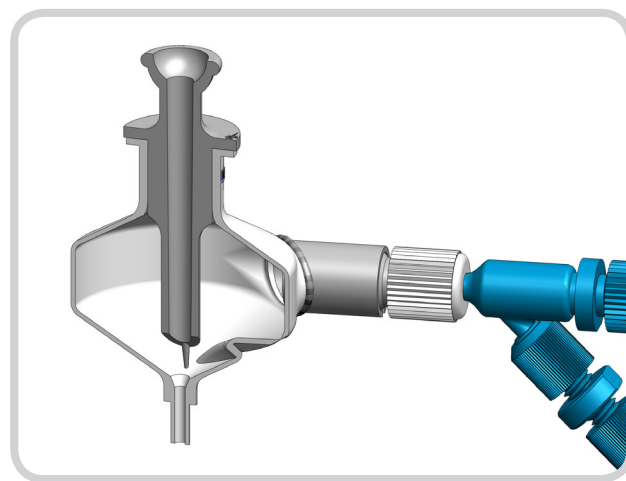

Shows exit port/connector 821-103 (with baffle and 12/5 socket connector). Protrusion at baffle tip promotes smooth draining. The lower part of the spoiler can be seen in cross section at the base of the chamber.

Improved Precision

The key to improving precision with inert spray chambers is to eliminate the build up of very large droplets, which can cause a spike in the signal when they fall into the drain. Problem areas include the base of the nebulizer port and around the drain port at the bottom of the chamber. The nebulizer port in the Savillex PFA CSC features a conical insert, which eliminates dead volume and also prevents formation of large droplets below the nebulizer tip, while a protrusion at the baffle tip promotes smooth draining. Another common problem is re-nebulization: since PFA (and also PTFE, PEEK) cyclonics do not wet well, droplets can be blown around the side walls by nebulizer gas (especially when a baffle is used). Droplets can travel around the circumference of the chamber, passing over the nebulizer port to be re-nebulized, causing a signal spike. The Savillex PFA CSC features a deep spoiler, molded into the side wall, that runs from the neck at the top of the chamber down to the drain. The spoiler prevents droplets from passing over the nebulizer port to be re-nebulized and also guides droplets down to drain. In combination, these features give the Savillex PFA spray chamber excellent signal stability and measurement precision, improving analytical data quality.

Summary

Savillex's stretch blow molding technology has enabled the development of a PFA spray chamber unique among inert spray chambers in that it allows the user to see inside the chamber during operation. Stretch blow molding also affords other key benefits including: use of the optimum cyclonic shape for performance, and reproducibility in manufacturing, leading to superior signal stability and excellent sensitivity. A proprietary surface treatment further enhances sensitivity around 40%, making the treated CSC comparable in sensitivity to the best glass and quartz cyclonics.